

DURATAPE RGBW 4.4W/FT
Product Code: DLHO44

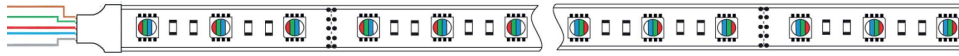

PRAPU Channel

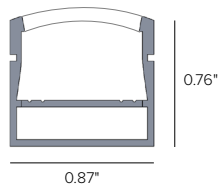

PRINU Channel

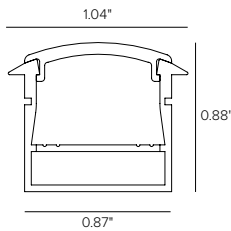

PRANU Channel

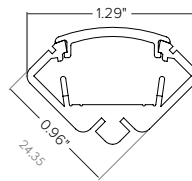
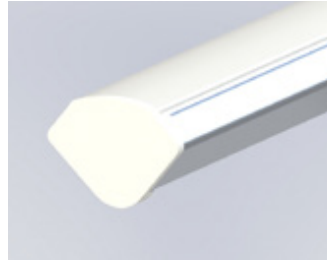

"IMPORTANT SAFETY INSTRUCTIONS

- Read all instructions.
- Do not conceal or extend exposed conductors through a building wall.
- For low voltage exposed insulated conductor systems, do not install any part of this system less than 7 feet (2.2 m) above the floor.
- To reduce the risk of fire and burns, do not install this lighting system where the exposed bare conductors can be shorted or contact any conductive materials.
- To reduce the risk of fire and overheating, make sure all connections are tight.
- Do not install any luminaire closer than 6 inches (15.25 cm) from any curtain, or similar combustible materials.
- Turn off electrical power before modifying the lighting system in any way.



MOUNTING INSTALLATION

Tape Installation

The recommended adhesive for attachment of our Channel to the stone work is to use a weatherproof Substructural Adhesive. For example, Liquid Nails or PL400 or both very good for adhesion to concrete and stone and also the polycarbonate and aluminum mounting channels that we supply.

The channel should be secured into position with a full coverage of the adhesive using blocks inserted into the gap width to allow the adhesive to cure for a minimum of 24 hours.

The Duratape can be attached directly to the channel, but it is necessary to be sure that the Channel surface is clean from dust and debris before attaching.

The Duratape product does have a 3M double sided tape, but we find that it is best to also use a thin bead weatherproof silicone added to the edges and ends when attaching. Again the use of blocks or sticks to secure the Duratape in position onto the channel should be done with 24 hours to cure before removing.

It is recommended that the Duratape is all test powered in position before attaching to be sure that no damage has occurred that will be difficult to repair once the product has cured into the channel.

Adhesive and clip

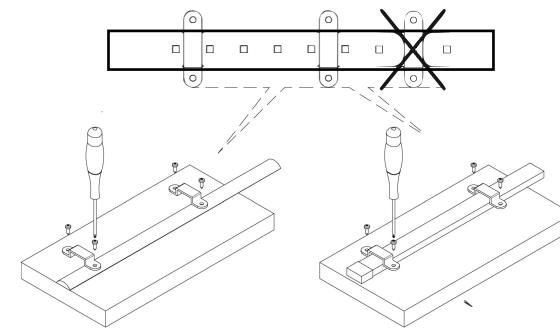

Only adhesive

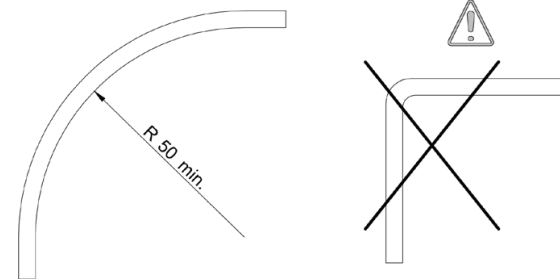
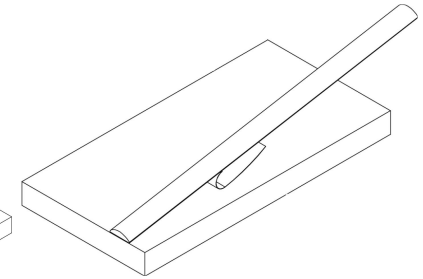

Channel Installation

Duratape PRAPU, PRINU, and PRANU all have mounting clips that hold the channel for a secure installation of any surface.

All channels must be installed by a qualified worker that will mount the product compliant to local building code.

Installer will first locate the area of installation and secure the clip onto the mounting surface with the correct mounting screw based on mounting surface. Be sure before securing to align the clips in a straight line before securing the clips on the mounting surface.

Once the mounting clip is aligned and secured on the mounting surface, the channel clips onto the mounting clip thus securing the channel into place.

